

# TUFFALOY TIP ADAPTERS

TUFFALOY threaded electrode adapters are used to provide longer electrode holder life, by providing a changeable tip socket in holders having threaded openings. Class 2 alloy. Other alloys available.

A Pipe Thread or Taper	B Taper Socket	C Body Size	D Body Length	E Over-All Length	Description	Part Number
1/2-14 NPT	4RW	1" Hex	1/4	7/8	AD-124-.8	190-1408
			3/8	1	AD-124-1.0	190-1410
			5/8	1-1/4	AD-124-1.2	190-1412
			7/8	1-1/2	AD-124-1.5	190-1415
			1-1/8	1-3/4	AD-124-1.7	190-1417
			1-3/8	2	AD-124-2.0	190-1420
			1-5/8	2-1/4	AD-124-2.2*	190-1425
			1-7/8	2-1/2	AD-124-2.5	190-1425
			2-1/8	2-3/4	AD-124-2.7*	190-1430
			2-3/8	3	AD-124-3.0	190-1430
			2-5/8	3-1/4	AD-124-3.2*	190-1435
			2-7/8	3-1/2	AD-124-3.5	190-1435
			3-1/8	3-3/4	AD-124-3.7*	190-1440
			3-3/8	4	AD-124-4.0	190-1440
			4-3/8	5	AD-124-5.0*	190-1440
			1/2-14 NPT	5RW	1" Hex	1/4
3/8	1	AD-125-1.0				190-1510
5/8	1-1/4	AD-125-1.2				190-1512
7/8	1-1/2	AD-125-1.5				190-1515
1	1-5/8	AD-125-1.6*				190-1517
1-1/8	1-3/4	AD-125-1.7				190-1520
1-3/8	2	AD-125-2.0				190-1520
1-5/8	2-1/4	AD-125-2.2*				190-1525
1-7/8	2-1/2	AD-125-2.5				190-1525
2-1/8	2-3/4	AD-125-2.7*				190-1530
2-3/8	3	AD-125-3.0				190-1530
2-5/8	3-1/4	AD-125-3.2*				190-1535
2-7/8	3-1/2	AD-125-3.5				190-1535
3-1/8	3-3/4	AD-125-3.7*				190-1540
3-3/8	4	AD-125-4.0				190-1540
3-7/8	4-1/2	AD-125-4.5				190-1545
5/8-14 NPT	4RW	1" Hex	1/4	7/8	AD-584-.8	190-2408
			3/8	1	AD-584-1.0	190-2408
			7/8	1-1/2	AD-584-1.5*	190-2408
			1-3/8	2	AD-584-2.0*	190-2408
5/8-14 NPT	5RW	1" Hex	1/4	7/8	AD-585-.8	190-2508
			3/8	1	AD-585-1.0*	190-2510
			5/8	1-1/4	AD-585-1.2	190-2512
			7/8	1-1/2	AD-585-1.5	190-2515
			1-1/8	1-3/4	AD-585-1.7	190-2517
			1-3/8	2	AD-585-2.0*	190-2517
			1-7/8	2-1/2	AD-585-2.5*	190-2517
			2-3/8	3	AD-585-3.0*	190-2517
3-3/8	4	AD-585-4.0*	190-2517			
3/4-14 NPT	5RW	1.25 Hex	3/16	1-1/8	AD-345-1.1*	190-3515
			7/16	1-3/8	AD-345-1.3*	190-3515
			9/16	1-1/2	AD-345-1.5	190-3515
			13/16	1-3/4	AD-345-1.7	190-3517
			1-1/16	2	AD-345-2.0	190-3520
			1-9/16	2-1/2	AD-345-2.5	190-3520
			2-1/16	3	AD-345-3.0	190-3530
			2-9/16	3-1/2	AD-345-3.5	190-3535
			3-1/16	4	AD-345-4.0	190-3540
			4-1/16	5	AD-345-5.0	190-3550
3/4-14 NPT	6RW	1.25 Hex	5/16	1-1/4	AD-346-1.2*	190-3613
			7/16	1-3/8	AD-346-1.3	190-3613
			9/16	1-1/2	AD-346-1.5	190-3615
			1-1/16	2	AD-346-2.0	190-3620
			1-9/16	2-1/2	AD-346-2.5	190-3625
			1-13/16	2-3/4	AD-346-2.7*	190-3630
			2-1/16	3	AD-346-3.0	190-3630
			2-9/16	3-1/2	AD-346-3.5	190-3635
			3-1/16	4	AD-346-4.0	190-3640
			3-9/16	4-1/2	AD-346-4.5	190-3645
4-1/16	5	AD-346-5.0	190-3650			
3/4-14 NPT	7RW	1.25 Hex	9/16	1-1/2	AD-347-1.5	190-3715
			1-1/16	2	AD-347-2.0	190-3720
			1-9/16	2-1/2	AD-347-2.5	190-3725
			2-1/16	3	AD-347-3.0	190-3730
			2-9/16	3-1/2	AD-347-3.5	190-3735
			3-1/16	4	AD-347-4.0	190-3740
4RW	5RW	1" Hex	1	2	AD-45-2	190-4520
			2	3	AD-45-3	190-4530
			3	4	AD-45-4	190-4540
			1/4	1-1/8	AD-54-1	190-5410
			1	2	AD-54-2	190-5420
5RW	4RW	7/8 Hex	1-1/2	2-1/2	AD-54-2.5*	190-5430
			2	3	AD-54-3	190-5430
			3	4	AD-54-4	190-5440
			1	2	AD-55-2	190-5520
5RW	5RW	7/8 Hex	1-1/2	2-1/2	AD-55-2.5	190-5525
			2	3	AD-55-3*	190-5525
			3	4	AD-55-4	190-5540
			4	5	AD-55-5	190-5550
5RW	6RW	1" Hex	1-1/8	2	AD-56-2	190-5620
			1/4	1-1/4	AD-64-1	190-6410
			1/4	1-1/4	AD-65-1	190-6510
			1/4	1-1/2	AD-74-1	190-7410
7RW	5RW	1" Hex	1/4	1	AD-75-1	190-7510
			3/4	2	AD-75-2	190-7520
			2-1/4	3-1/2	AD-75-3.5*	190-7520
			2-3/4	4	AD-75-4*	190-7520

\* Not commonly stocked - other adapters available upon request

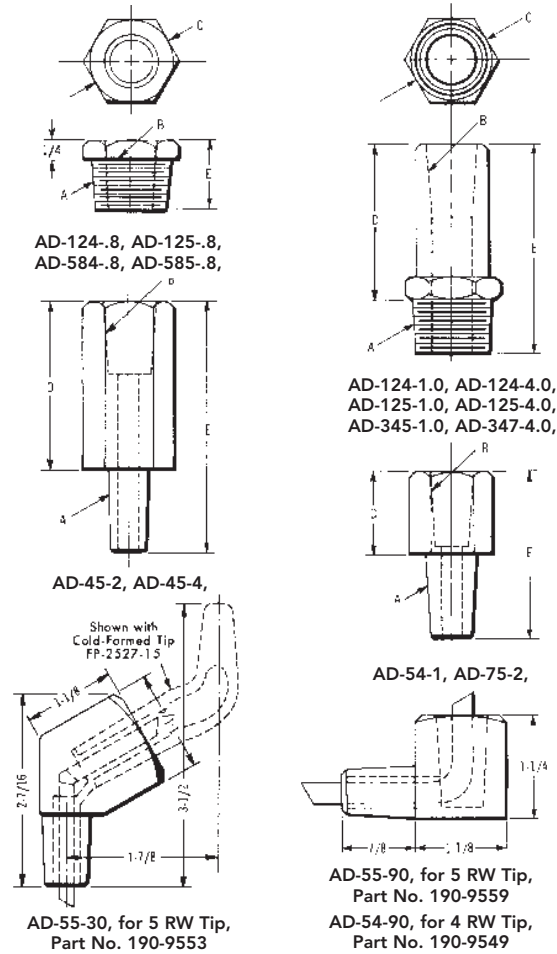

## STRAIGHT THREADED ADAPTERS FOR MULTI-SPOT BARREL AND CLAMP

A	B	Description	Part No.
<b>4 RW TAPER - 7/8-14 NF</b>			
3/8	1-1/8	AD-134-1.1	190-3211
1/2	1-1/4	AD-134-1.2	190-3212
5/8	1-3/8	AD-134-1.3	190-3213
3/4	1-1/2	AD-134-1.5	190-3215
1	1-3/4	AD-134-1.7	190-3217
1-1/4	2	AD-134-2.0	190-3220
1-1/2	2-1/4	AD-134-2.2	190-3222
1-3/4	2-1/2	AD-134-2.5	190-3225
2-1/4	3	AD-134-3.0	190-3230
2-3/4	3-1/2	AD-134-3.5	190-3250
<b>5 RW TAPER - 7/8-14 NF</b>			
3/8	1-1/8	AD-135-1.1	190-3311
1/2	1-1/4	AD-135-1.2	190-3312
5/8	1-3/8	AD-135-1.3	190-3313
3/4	1-1/2	AD-135-1.5	190-3315
1	1-3/4	AD-135-1.7	190-3317
1-1/4	2	AD-135-2.0	190-3320
1-1/2	2-1/4	AD-135-2.2	190-3322
1-3/4	2-1/2	AD-135-2.5	190-3325
2-1/4	3	AD-135-3.0	190-3330
2-3/4	3-1/2	AD-135-3.5	190-3335
<b>5 RW TAPER - 1-12 NF</b>			
3/8	1-1/8	AD-105-1.1	190-4311
1/2	1-1/4	AD-105-1.2	190-4312
5/8	1-3/8	AD-105-1.3	190-4313
3/4	1-1/2	AD-105-1.5	190-4315
1	1-3/4	AD-105-1.7	190-4317
1-1/4	2	AD-105-2.0	190-4320
<b>5 RW TAPER - 1-12 NF</b>			
1-1/2	2-1/4	AD-105-2.2	190-4322
1-3/4	2-1/2	AD-105-2.5	190-4325
2	2-3/4	AD-105-2.7	190-4327
2-1/4	3	AD-105-3.0	190-4330
2-3/4	3-1/2	AD-105-3.5	190-4335

194-2085  
1-3/8 D.  
Barrel  
Required  
for 1-12 NF  
Adapter



**MULTI-SPOT BARREL AND CLAMP**

**TUFFALOY**

**101 SERIES HOLDERS (For 4 & 5 RW Tips)**

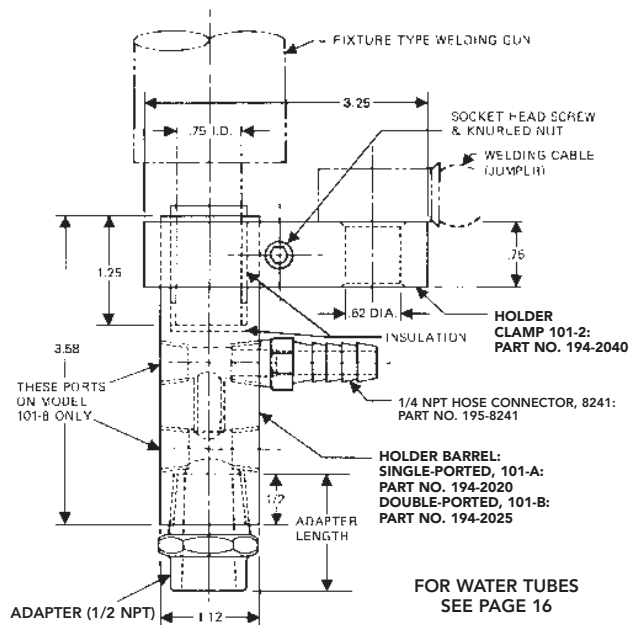

To determine distance adapter sticks out from holder, deduct 1/2" from length of adapter selected. Water tubes 1/2" longer than adapter will install approximately flush with adapter face.

**102 SERIES HOLDERS (For 6 & 7 RW Tips)**

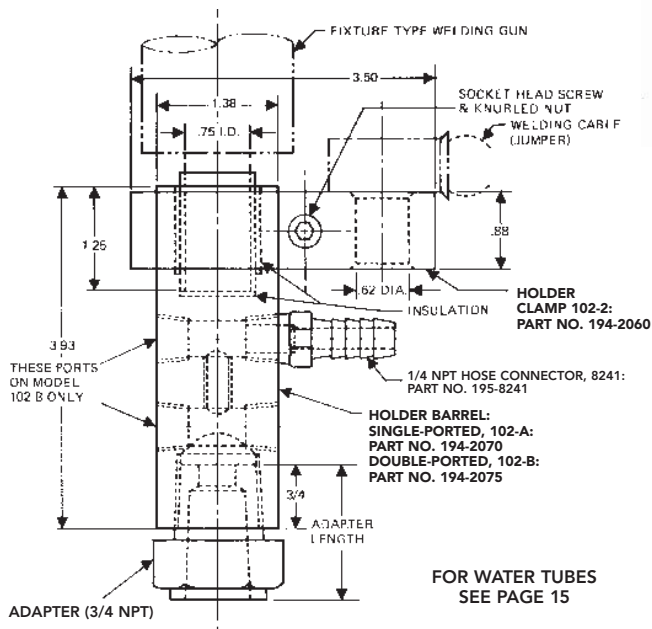

To determine distance adapter sticks out from holder deduct 3/4" from length of adapter selected. Water tubes 3/4" longer than adapter will install approximately flush with adapter face.

**STRAIGHT HOLDERS**

Straight holders for multi-spot welding are available in two sizes, to carry tips having four different diameters. Series 101 holders are for 4 & 5RW tips, and Series 102 holders are for 6 & 7RW tips. They may be ordered with one or two sets of coolant ports.



Mating electrical contact surfaces of both the barrels and the clamp are silver plated. Item Numbers for replacement barrels and clamp parts are called out on the drawings.

Threaded adapters for barrels can be found on page 16.

194-2080 Barrel Only for 7/8 - 14 NF Adapter  
194-2081 Barrel Only Dual w/Con. @ 20° Offset for 7/8 - 14 NF Adapter

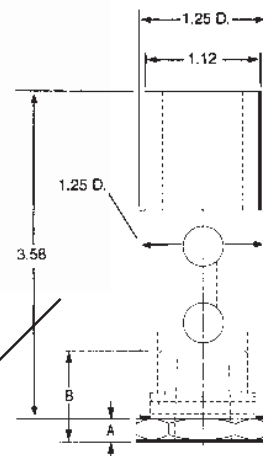

**CLAMP AND BARREL ARE SEPARATE PARTS**

Adapters, water connectors and water tubes (see page 15 & 16) are sold separately.

HOLDERS and CLAMPS						
Holders For Tip Sizes	Number of Coolant Ports					
	One Set		Two Sets		Clamp	
	Description	Part No.	Description	Part No.	Description	Part No.
4 & 5 RW	101-A	194-2020	101-B	194-2025	101-2	194-2040
6 & 7 RW	102-A	194-2070	102-B	194-2075	102-2	194-2060
4 & 5 RW	103-A	194-2080	103-B	194-2081	101-2	194-2040
5 RW			SH-102-B	194-2085	102-2	194-2060

194-2085 (1-3/8 diameter barrel) only for 1-12 NF adapter

